

DOCUMENTATION

Electronic Heat Cost Allocator EURIS II



INNOTAS ELEKTRONIK GMBH



March 27/ 2012

Issued by: INNOTAS Elektronik GmbH

1 Table of contents

2	REVISIONS HISTORY	1
3	DEVICE TYPES	2
3.1	1-SENSOR TYPE	2
3.2	2-SENSOR TYPE	2
3.3	OPTION RF INTERFACE.....	2
3.4	OPTION OPTICAL INTERFACE	2
3.5	OPTION REMOTE SENSOR	2
4	YELLOW KEY.....	3
5	DISPLAY	3
5.1	STRUCTURE OF DEVICE MENU.....	3
5.1.1	MENU STORAGE MODE.....	4
5.1.2	MAIN MENU	5
5.1.3	MENU CONSUMPTION VALUES	6
5.1.4	SERVICE MENU	7
6	SELF-MONITORING.....	8
6.1	TAMPER RECOGNITION.....	8
6.2	SENSOR MONITORING	8
6.3	BATTERY MONITORING.....	8
6.4	RESET MONITORING	8
6.5	MONITORING OF MEMORY	8
7	MOUNTING AND START UP	9
7.1	MOUNTING	9
7.1.1	MOUNTING ACCESSORIES	10
7.1.2	MOUNTING OF EURISII.....	12
7.2	START UP OF OPERATION	13
8	PARAMETERISATION	13
9	RADIATOR REVIEW.....	14
9.1	KC-VALUES.....	14
9.2	SCALING.....	14
9.3	CONSUMPTION VALUE.....	14
9.3.1	WITH ASSESSED VALUATION IS VALID	14
9.3.2	BY PRODUCT EVALUATION IS VALID	14
10	TECHNICAL DATA	15
11	WARNING AND SAFETY NOTES	15
12	TABLE OF ILLUSTRATIONS.....	16

2 Revisions history

REVISION	DATE	CHANGES
1.0	June/ 17/ 2011	First Issue
1.1	September 2011	Fix grafik
1.4	Januar 2012	Absatz Prüfzahl ergänzt, Kapitel 9.3 gemäß WTP ergänzt
1.5	March 2012	Optische Verlängerung und langes Funkprotokoll ergänzt
1.6	March 2012	Darstellung Stichdatum, Schutzgrad ergänzt

DOCUMENTATION

ELECTRONIC HEAT COST ALLOCATOR EURIS II

3 Device types

EURIS II is available in following device types:

Device type	Options		
	RF	Optical interface	Remote sensor
1-Sensor type	X	X	
2-Sensor type	X	X	X

3.1 1-Sensor type

1-Sensor type of electronic heat cost allocator EURISII measures the temperature of the radiator and calculates the consumption arising the difference against a given fixed (room) temperature of 20°C. The design temperature of radiator has to be between 55°C and 95°C.

3.2 2-Sensor type

2-Sensor type of electronic heat cost allocator EURISII measures both the temperature of the radiator and the room temperature with the second temperature sensor. The achieved metering precision is higher than at 1-Sensor type devices. The design temperature of radiator is between 35°C and 95°C. In combination with remote sensor is the max. design temperature of radiator 105°C. radiator delivery temperature at 105°C.

3.3 Option RF Interface

As RF Interface the standardized (according to DIN EN13757-4) wM-BUS RF communication is used. RF parameters can be set using the contact interface on backside or optical interface (option). With PC-program „EURISII-Commander“ can be set all parameters as times, cycles, modes (S1, T1) or AES128 encryption. (See documentation “EURISII Commander“)

3.4 Option Optical Interface

All variations of heat cost allocator EURISII have a contact interface, where can be made the parameterisation before mounting the device on radiator. The optical interface option offers additionally the opportunity of parameterisation and read out the device without dismounting the device from radiator. There is used a standard IR opto interface in combination with a computer and the „EURISII-Commander“ software. To start the communication it is necessary to press the yellow key, the interface is then active for 15s.

3.5 Option Remote Sensor

Option Remote sensor is available for 2-Sensor types. The radiator sensor is implemented as remote sensor (cable length 2m). Remote sensor will be mounted on the radiator according to mounting instructions, the heat cost allocator device can be mounted beside the radiator at any desired place.

4 Yellow Key

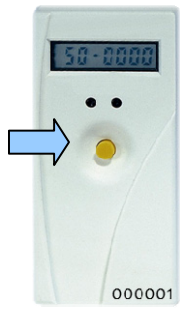

4-1 KEY ON EURISII

Operation of heat cost allocator EURISII is done by using the yellow key in the middle of the housing of the device. There are two operating modes: pressing the key short (short key operation) or longer than 3s (long key operation). Users haven't to count the duration of pressing the key for long key operation, the display indication changes automatically to the desired mode. After 30s the display indication falls back to sleep mode without pressing the key.

Abbreviations: LK – long key operation (3 seconds)
SK – short key operation

5 Display

EURISII heat cost allocator has a 7 1/2 digit display. The display indication is OFF during normal operation. If a read out of values or a communication via interface is desired by user, it is necessary to "wake up" the device by pressing the key shortly. Without further operation on the key the EURISII switches to „sleep mode“ and the display indication turns OFF.

5.1 Structure of device menu

Display indication is splitted on 4 levels. First level is the indication in storage mode, in which the device will be delivered before mounting on radiator and setting into operation. All other levels are available after mounting on radiator via pressing the yellow key (main menu, consumption values, service menu).

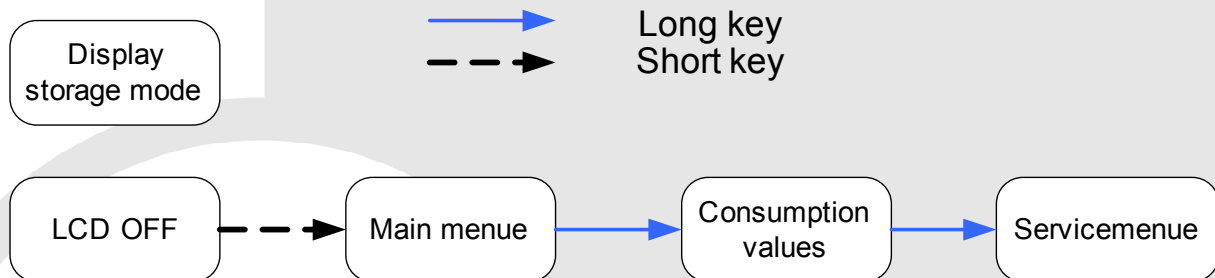

5-1 STRUCTURE OF MENU

5.1.1 Menu storage mode

Heat cost allocators EURISII get standard parameters or parameters requested by customers ex works. After parameterisation and test device will be set to storage mode. The device is inactive, display indication is off. After short key operation the display indication is blinking as follows:

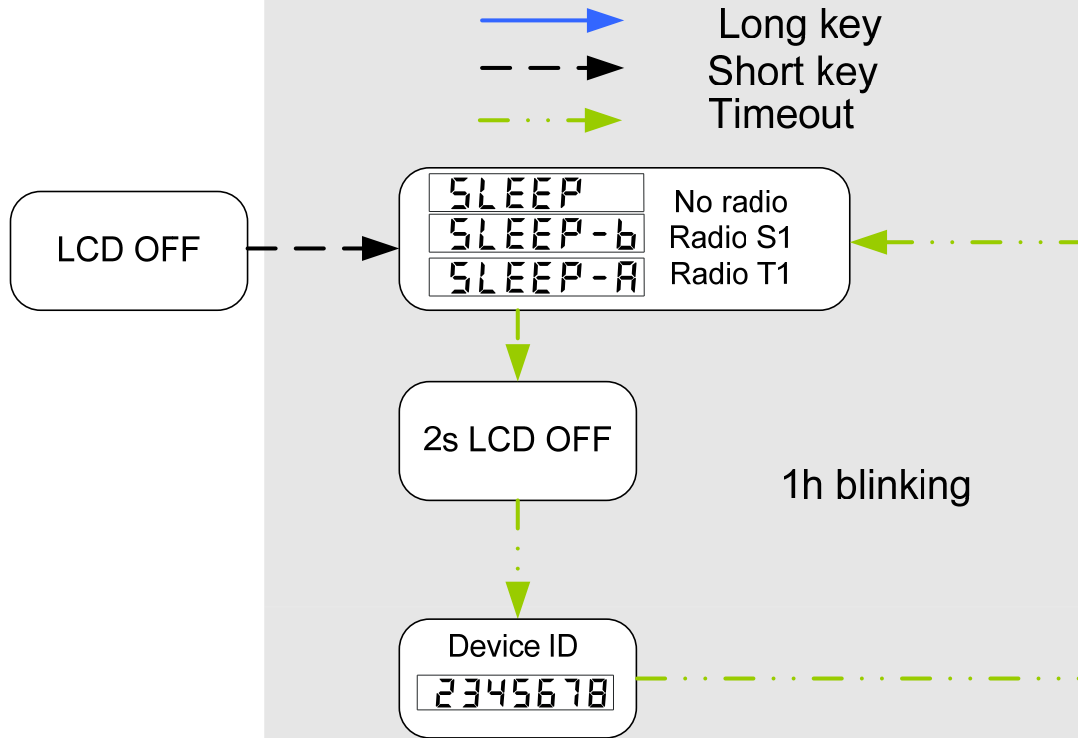

5-2 DISPLAY INDICATION IN STORAGE MODE

5.1.2 Main menu

After mounting the EURISII device on radiator and setting it into operation main menu is activated by short key operation. Display switches off after 30s without key operation.

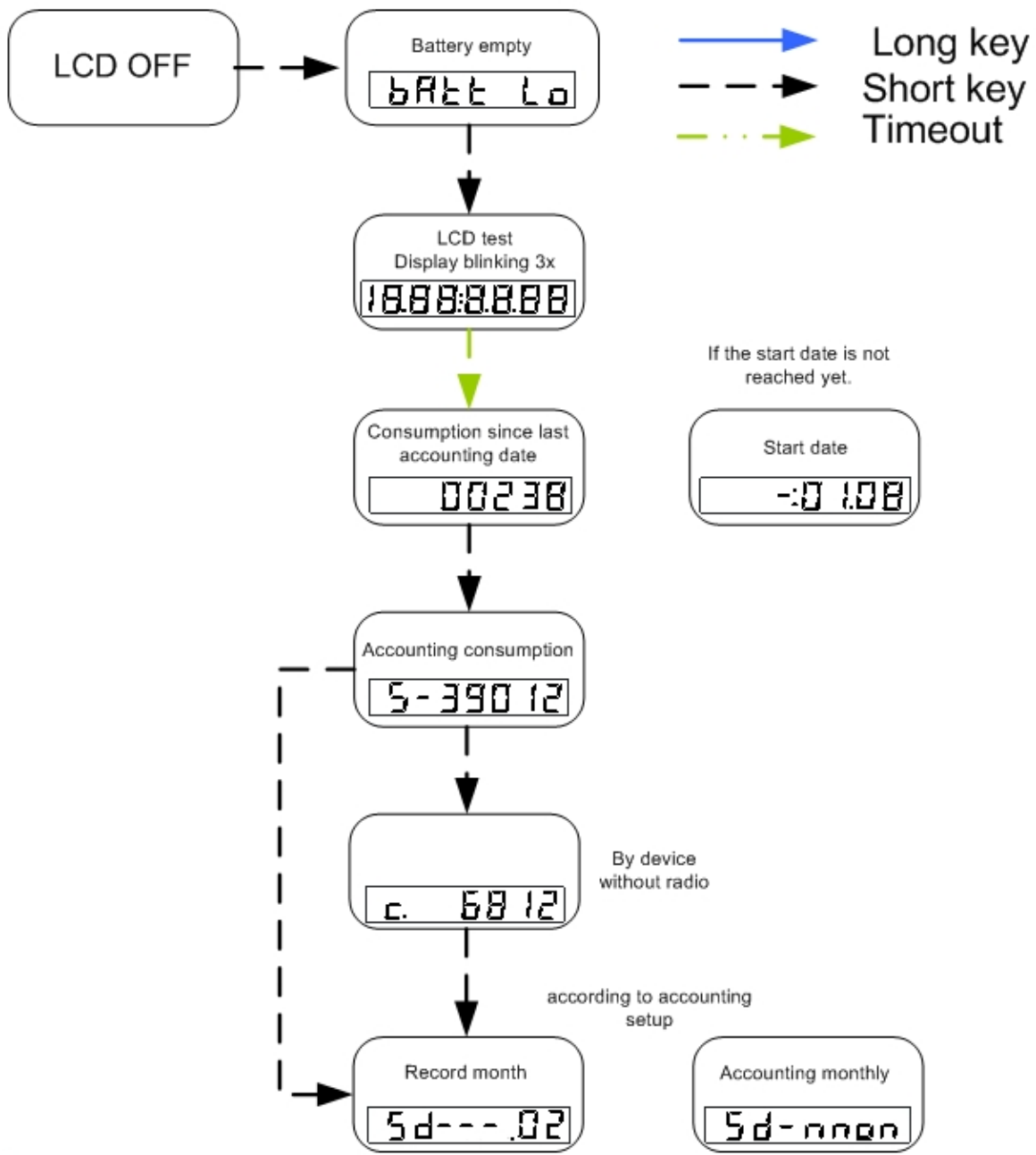

5-3 MAIN MENU

5.1.3 Menu consumption values

Menu consumption value will be activated by a long key operation from any point of main menu. After expiration of 30s without key operation display indication turns off.

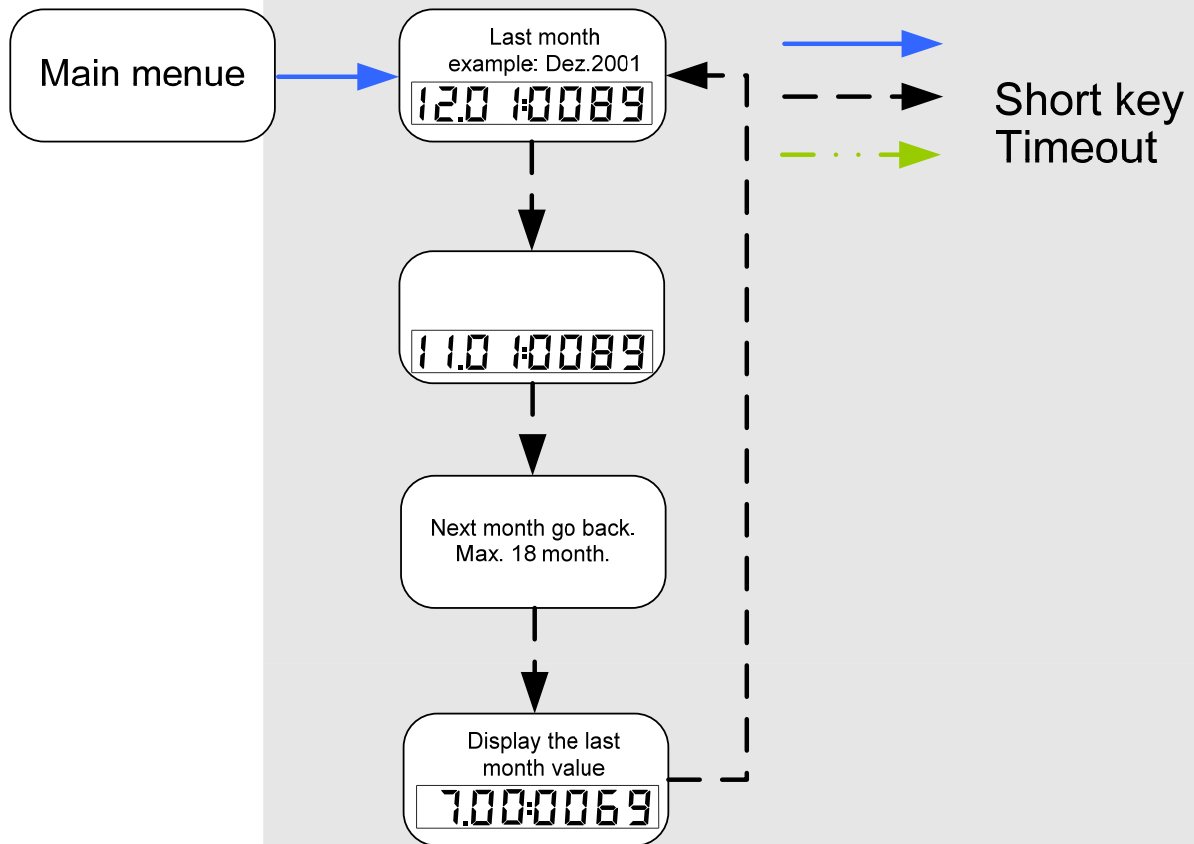

5-4 CONSUMPTION MENU

5.1.4 Service menu

Service menu will be activated by long key operation from any point of consumption menu. After expiration of 30s without key operation display indication turns off.

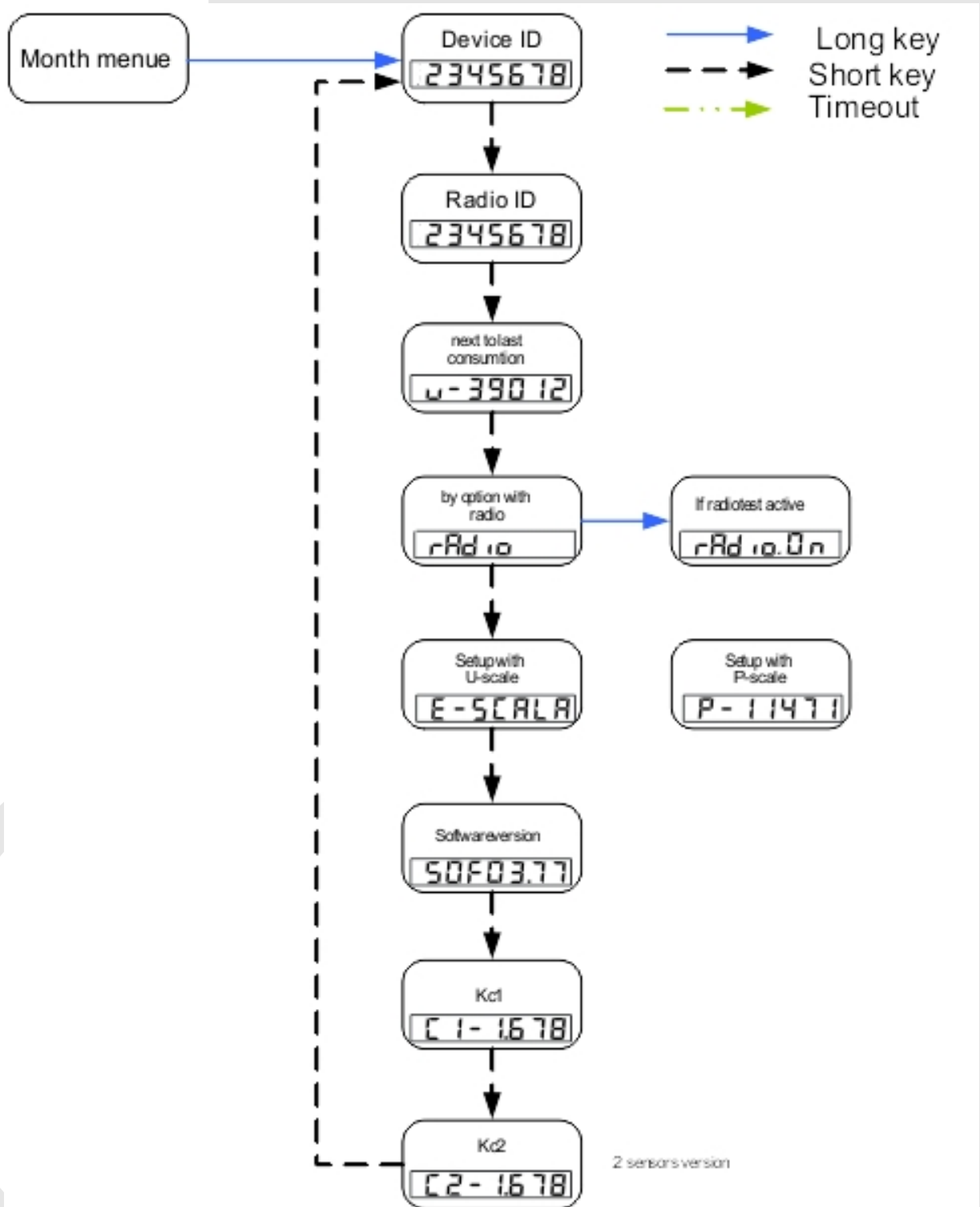

5-5 Service menu

6 Self-monitoring

Heat cost allocator EURISII is monitoring the most important basic functions to secure a proper operation and still signalling appearing errors and malfunctions.

6.1 Tamper recognition

The implemented tamper recognition is monitoring the illegal dismantling of device from radiator. A separation of the device from metallic heat conductor will be recognised and signalled by setting an error bit. Heat cost allocator device keeps in operation. The set error bit will be considered in calculation of checksum at next record date, will be transmitted via RF or read out via interface. Tamper recognition is activated automatically within next 24h after mounting the device on radiator and start up of operation. The error bit can be reset via interface communication.

6.2 Sensor monitoring

Sensor monitoring recognises a short or a break of temperature sensor. If one of these errors is recognised repeated a error bit will be set after app. 40min. The heat cost allocator device isn't able to get measuring values now. This error will be signalled by turning on the display an "Error" indication. The set error bit will be considered in calculation of checksum at next record date, will be transmitted via RF or read out via interface. The error bit can be reset via interface communication. Sensor monitoring is activated automatically after start up of operation.

6.3 Battery monitoring

The implemented battery guarantees a device lifetime of 10 years (2 additional years as reserve) at normal operation. „Batt lo“ error will be set after 11 years device operation ex work or lower voltage deviation during RF transmission. EURISII heat cost allocator has from this point an operating reserve, which duration varies depending on battery load (RF, low ambient temperature etc.) When the error bit is set, the display indicates „Batt lo“ after short key operation before display self-test. Batt lo“. The set error bit will be considered in calculation of checksum at next record date, will be transmitted via RF or read out via interface. The error bit can be reset via interface communication. Battery monitoring is activated ex works.

6.4 RESET monitoring

EURISII heat cost allocator device recognises a re-start of the implemented software after malfunction. The set error bit will be considered in calculation of checksum at next record date, will be transmitted via RF or read out via interface.

6.5 Monitoring of memory

EURISII is monitoring the correctness of set parameters. If an error is recognised a checksum error will be set. The set error bit will be considered in calculation of checksum at next record date, will be transmitted via RF or read out via interface.

7 Mounting and Start up

EURISII heat cost allocator device will be delivered packed ex works, operating in storage mode (display indication is OFF). Only after short key operation display shows indication according to point 5.3.3. for 1 hour. The device is inactive in storage mode, only the implemented clock is running. EURISII will be delivered with the following standard parameters (if there are no special custom requested parameters):

- German winter time (UTC+1h)
- Unity scale
- No measuring-free summer months
- Immediate start of measuring after start up of operation
- Record date annual on January 1-st 00:00 o'clock
- RF w-MBUS mode T1, every work day from 7 a.m. to 5 p.m., cycle frequency 30s, transmission variance of 11s, without AES128 encryption

7.1 Mounting

Permissible tolerance of mounting height: ± 10 mm.

If it is not possible to comply with the right mounting place due to the construction of the radiator, mounting will be done as follows regarding to:

from radiator midpoint → in direction valve

from radiator height (75%/50%) → offset upward

7.1.1 Mounting accessories

7.1.1.1 Heat conductor-adaptor wide / 52



7-1 HEAT CONDUCTOR WIDE

Suitable for types of radiators with special constructions or big distance between gills. It will be mounted behind the standard heat conductor.

7.1.1.2 Heat conductor (aluminium)

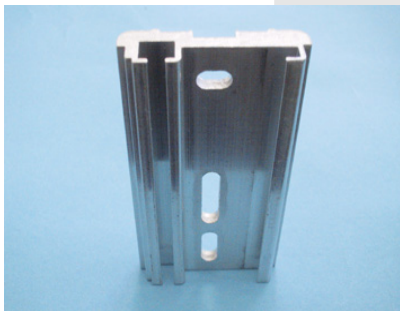

7-2 STANDARD HEAT CONDUCTOR

Standard-heat conductor (part of standard accessory of every EURISII).

7.1.1.3 Seal

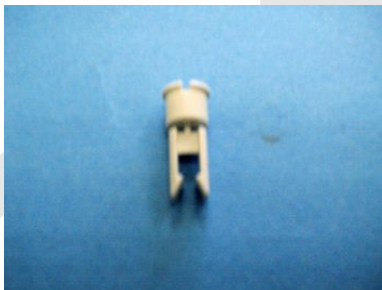

7-3 SEAL

For correct fixing the EURISII on heat conductor (part of standard accessory of every EURISII).

7.1.1.4 Flat- and special radiators



7-4 ACCESSORIES FOR FLAT AND SPECIAL RADIATORS

Welding stud:

M3x10

M3x12

M3x15

shank nut M3

shank nut M3

7.1.1.5 Sectional radiator

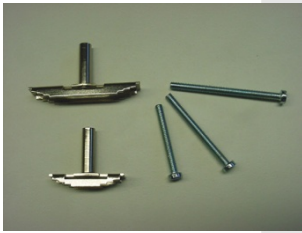

7-5 ACCESSORIES FOR SECTIONAL RADIATORS

slide nut 33/51 (55mm)

slide nut 14/32 (36mm)

Please mount with bolt M4x35 / M4x45 / M4x55 according to demand!

7.1.1.6 Tube radiators



7-6 ACCESSORIES FOR TUBE RADIATORS

slide nut for tube (36mm)

slide nut for tube (45mm)

Please mount with bolt M4x35 / M4x45 / M4x55 according to demand!

7.1.1.7 Convector heater



7-7 ACCESSORY FOR CONVECTOR HEATER

U-bolt set complete

7.1.1.8 Aluminium radiator



7-8 ACCESSORY FOR ALUMINIUM RADIATOR

2 toggles for aluminium radiators. Mounting with 2 bolts M3x25
alternatively: 2 sheet metal screws 4,2x25

7.1.1.9 Optische Verlängerungen

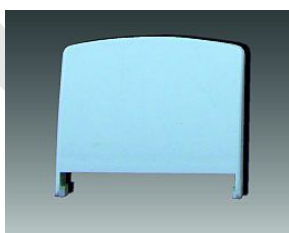

7-9 ZUBEHÖR FÜR RÖHRCHENUMBAU

2 optical lengthening for covering of resulted colour damages after the changeover of tube on HKV.

7.1.2 Mounting of EURISII



7-11 MOUNTING OF HEAT CONDUCTOR

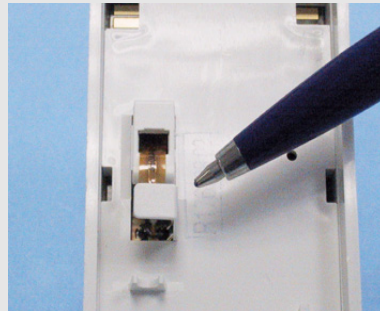

7-10 SENSOR COVER

Heat conductor has to be mounted on radiator in accordance to mounting instructions (slotted holes downward). Remove the sensor cover on backside of EURISII (see Illustration 7-11 Removing sensor cover 2)

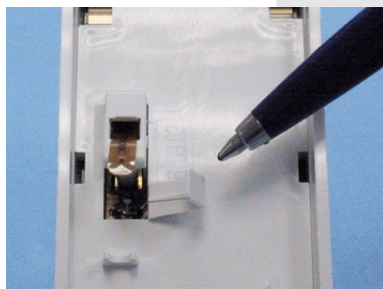

7-12 Removing sensor cover 1

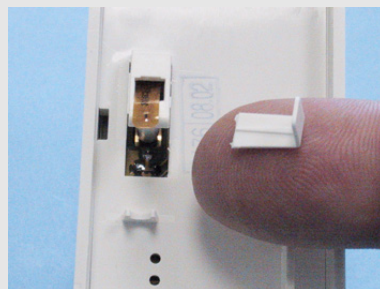

7-13 REMOVING SENSOR COVER 2

Slide the cover sideways to the centre of EURISII and dismantle it.



Attention: Do not bend the temperature sensor!



7-14 MOUNTING EURISII ON HEAT CONDUCTOR



7-15 INSERTING THE SEAL

Hook the EURISII device with its 2 hooks at the inside of housing into the upper end of heat conductor, press it down and insert the seal at the lower side. The seal is on the right place, when it is snapped in.

7.1.2.1 Note about welding bolts

Sound impulses can be emitted during welding the bolt onto the radiator, where pets are responding sensitively. Please keep pets out of rooms where the bolts are welded.

7.1.2.2 General restrictions

It is not allowed to use EURISII heat cost allocator on steam heating, underfloor heating or ceiling-mounted radiation heating. The use on combined valve and flap controlled radiator isn't allowed too, unless the flap control is dismantled or inoperative. The use of EURISII heat cost allocator on radiator with additional blower or heating cartridges is only admissible, if these additional electrical devices are in operatively.

7.2 Start up of operation

After mounting on radiator the EURISII heat cost allocator can be set into operation. Press the yellow key longer than 3s (long key operation). EURISII switches from turns to operating mode now. It starts with display test (blinking elements) and indicates first point of main menu (see also 5.1.2). According to the previous or ex works setting the device start the measuring. If the RF option is implemented, it is transmitting installation telegram additionally to regular telegrams every 30s for 1hour..

8 Parameterisation



8-1 INTERFACE CONTACTS OF EURISII

EURISII heat cost allocator can get the parameters as well via optical interface (option) as via contact interface.

Contact interface is situated on bottom side of the device, left above temperature sensor.



Attention: Please contact this interface with fitting adaptor to ensure a correct data transmission!



8-2 ADAPTOR FOR CONTACT INTERFACE

The adaptor has a power supply and cable to connect with the RS232 or USB interface of a computer.



Attention: The contact interface can be used only before mounting the EURISII device on the radiator and with the appropriate adaptor and software!

Before starting data transmission between EURISII and computer please activate the interface by short key operation. The interface is active for 15s. Further details are provided in the software manual.



8-3 EURISII WITH OPTICAL HEAD

Setting parameters and read out of data can be done also via optical interface (option) using a IR opto-interface device (optical head with write/read function). This optical device will be connected to your PC or Pocket-PC. If you have an EURISII heat cost allocator with optical interface option, it is more convenient to communicate with the device after mounting on radiator than using the contact interface.

9 Radiator review

Radiator review can be made by qualified specialists only.

9.1 KC-values

The Conversion of a read out value of heat cost allocator EURISII to a billable consumption value for creation of a correct bill of utility cost will be done using a Kc – weighting factor. This factor is dependent on radiator type. Only using the corresponding Kc-factor guarantees a correct billing of heat consumption. A list of Kc-factors is available on demand.

9.2 Scaling

The EURISII device can be set to unity or product scale configuration. Standard configuration is unity scale. In case of using product scale every EURISII heat cost allocator has to be configured dependent on radiator, where it will be mounted on.

9.3 Consumption value

each with: $K_1 = \frac{1}{(1-C_{1F})}$ und $K_2 = \frac{1}{(1-C_{2F})}$ sowie $K_Q = \frac{Q_{60}}{1000W}$ mit Q_{60} in Watt

9.3.1 With assessed valuation is valid

1F-compact und 1F-remote sensor (1FF)

The internal assessed valuation occurs with $K_Q * K_T = 1$, $K_{1F} = 1$

The correction of the read values occurs after following formula:

$$\text{consumption value} = \text{reading value} * K_Q * K_T * \left(\frac{K_1}{1,0}\right)^{1,15}$$

The value of K1 of the used heater is to be taken from the C-value table of the EURISII.

KT is the evaluation factor for rooms with low interpretation inside temperatures (<16°C)

2F-compact (2F)

The internal assessed valuation occurs with $K_Q = 1$, $K_1 = 1,538$, $K_2 = 2,5$

The correction of the read values occurs after following formula:

$$\text{consumption value} = \text{reading value} * K_Q * \left(\frac{K_2}{2,5}\right)^{1,15}$$

The value of K2 of the used heater is to be taken from the C-value table of the EURISII.

2F-remote sensor (2FF)

The internal assessed valuation occurs with $K_Q = 1$, K_1 und $K_2 = 1,538$

The correction of the read values occurs after following formula:

$$\text{consumption value} = \text{reading value} * K_Q * \left(\frac{K_2}{1,538}\right)^{1,15}$$

The value of K2 of the used heater is to be taken from the C-value table of the EURISII.

9.3.2 By product evaluation is valid

1F- und 2F - model

The HKV is internal with KQ, K1 and K2 valued. The values of K1 and K2 of the used one Of heater are to be taken from the C-value table of the EURISII.

The values KQ K1 K2 in the EHKV are to be entered in each case with 1000 advanced.

$$\text{consumption value} = \text{reading value[kW]}$$

10 Technical Data

Standards	DIN EN 834 (November 1994),DIN EN 13757-4
Principle of measurement	2-sensors / (1-sensor)
Operation limits of temperature	Compact type $t_{\min}/t_{\max} = 35^{\circ}\text{C}/95^{\circ}\text{C}$ ($55^{\circ}\text{C}/95^{\circ}\text{C}$)
2-sensor type (1-sensor type) operating temperature	Remote sensor $t_{\min}/t_{\max} = 35^{\circ}\text{C}/105^{\circ}\text{C}$ $0^{\circ}\text{C}\dots 55^{\circ}\text{C}$
storage temperature	$-25^{\circ}\text{C}\dots 55^{\circ}\text{C}$ short-term 70°C
Microprocessor	8 Bit - Cotroller
Type of temperature sensor	2 sensorsNTC (1 sensor at 1F)
Display	LCD with $7^{1}/_{2}$ digits
Operation	Key, contact interface, optical interface (option)
Tamper recognition	Mechanical rcognition-seal, electronical recognition-contact
Scaling	Unity or product scale
Power supply	3 V-DC lithium battery
Delivery	Storage mode (measuring not active)
Operating lifetime with one battery	10 + 2 (reserve) years
Radiators normalised power	Up to 10.000 W with product scale
Memory	Last 18 month consumption values
Measuring cycle	4 minutes
Error indication	In service menu and check number
Read out	LCD / optical interface (option) or RF transmission (option) oder Funk
RF interface	W-MBUS in S1 or T1 mode according to DIN EN13757-4
Encryption of RF data	AES 128 Mode 5
Self-Monitoring	Tamper recognition, sensor function, operating time, Reset, Data
Label	Approval according to german HKVO
After protective degree DIN 40050	IP 41

11 Warning and safety notes



It is not allowed to use EURISII heat cost allocator on steam heating, underfloor heating or ceiling-mounted radiation heating. The use on combined valve and flap controlled radiator isn't allowed too, unless the flap control is dismantled or inoperative. The use of EURISII heat cost allocator on radiator with additional blower or heating cartridges is only admissible, if these additional electrical devices are in operatively. Electronic heat cost allocator EURISII device contains a Li-battery, which has to be disposed properly.



12 Table of illustrations

4-1 Key on EURISII	3
5-1 structure of menu	3
5-2 Display indication in storage mode	4
5-3 Main menu	5
5-4 consumption menu	6
5-5 Service menu	7
7-1 heat conductor wide	10
7-2 standard heat conductor	10
7-3 Seal	10
7-4 accessories for flat and special radiators	10
7-5 accessories for sectional radiators	11
7-6 Accessories for tube radiators	11
7-7 Accessory for convector heater	11
7-8 Accessory for aluminium radiator	11
7-9 SENSOR COVER	12
7-10 MOUNTING OF HEAT CONDUCTOR	12
7-11 Removing sensor cover 2	12
7-12 Removing sensor cover 1	12
7-13 INSERTING THE SEAL	12
7-14 MOUNTING EURISII ON HEAT CONDUCTOR	12
8-1 Interface contacts of EURISII	13
8-2 Adaptor for contact interface	13
8-3 EurisII with optical head	13